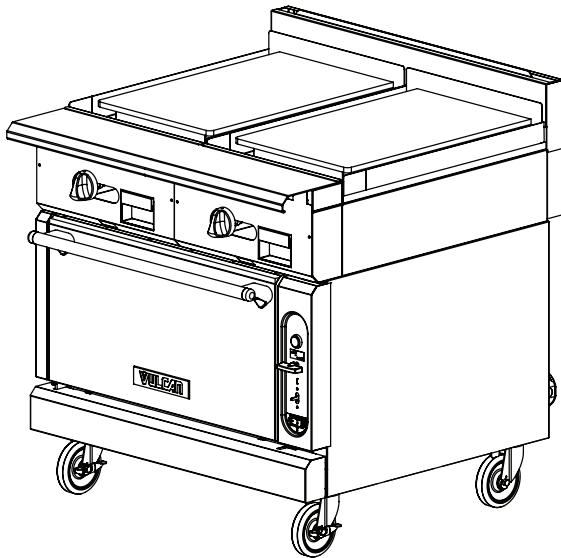

**HEAVY DUTY COOKING****VULCAN****HEAVY DUTY GAS RANGE**  
**36" Wide Dual Plancha Gas Range****V2P36C**

(shown on convection oven base)

**SPECIFICATIONS**

36" wide heavy duty gas range, Vulcan model No. V2P36 (modular), V2P36B (cabinet base), V2P36S (standard oven base) or V2P36C (convection oven base). Modular construction for ease of installation. Stainless steel front, front top ledge, plate ledge, sides, base, burner box, exterior bottom, stub back, and 6" adjustable legs on all "B", "S", & "C" models. Stainless steel extra deep crumb tray. Two 17,500 BTU/hr burners. Individual pilots and controls for each burner. 1/2" polished steel griddle plate with 3 sided grease trough. Standard oven: 50,000 BTU/hr with porcelain oven bottom, sides, and interior door panel. Convection Oven: 32,000 BTU/hr with porcelain oven bottom, sides, and interior door panel (115v- 1phase blower motor, 4 amps, 9' cord & plug). Ovens measure 27"w x 27"d x 13"h. Standard oven thermostats adjust from 150°-550°F. Convection oven adjusts from 175°-550°F and the optional finishing oven for standard ovens adjusts from 300°- 650°F. Standard oven supplied with one rack, convection oven with two. Both ovens allow for three rack positions. Oven door is heavy-duty with counter weight door hinges. 1/4" front manifold connection and 1/4" rear gas, capped.

**Exterior Dimensions:**36<sup>3</sup>/<sub>4</sub>"d x 36"w x 40<sup>1</sup>/<sub>2</sub>"h on 4" adjustable legs

- V2P36** 36" Wide Dual Plancha / Modular
- V2P36B** 36" Wide Dual Plancha / Cabinet Base
- V2P36S** 36" Wide Dual Plancha / Standard Oven
- V2P36C** 36" Wide Dual Plancha / Convection Oven

**STANDARD FEATURES**

- Stainless steel front, front top ledge, burner box, sides, base, exterior bottom and stub back
- 1/4" diameter front gas manifold with 1/4" rear gas connection (capped)
- 17,500 BTU/hr. burners (2 each)
- 50,000 BTU/hr. standard oven burner
- 32,000 BTU/hr. convection oven burner
- Individual pilots and controls for each burner
- 1/2" polished steel plate
- 3 sided grease trough
- 4" stainless steel stub riser
- 6" adjustable stainless steel legs for "B" models (no legs for modular model)
- Stainless steel cabinet base doors
- Universal rack guides, with one removable shelf (cabinet base)
- One year limited parts and labor warranty

**Optional Features (Factory Installed)**

- 1/4" rear gas connection
- Cap and cover front manifold
- 650°F oven thermostat and steel hearth ("S" models)
- 4" adjustable flanged feet for modular models
- 6" adjustable flanged feet for "S", "C", and "B" models
- Less legs for dolly mounting of cabinet base models
- Set of 4 casters, 6" high (two locking)
- 3" high toe base for curb mounting of cabinet base models
- 3/4", 1", or 1/4" gas pressure regulator (specify gas type- pack loose)
- Universal rack guides, with one shelf (shelf is removable)
- Common condiment type, telescoping plate rails

**ACCESSORIES (Packaged & Sold Separately)**

- Extra removable shelves for use with Universal rack guides (cabinet base)
- Banking strip
- Common condiment type, telescoping plate rails (starting at 24" length")
- 10", 22", or 34" high back risers (no shelf)
- 22" single deck solid or flo-thru high shelf risers
- 34" double deck solid or flo-thru high shelf risers
- Dolly frames
- Flexible gas hose with quick disconnect and restraining device

**VULCAN**

a division of ITW Food Equipment Group LLC

P.O. Box 696 ■ Louisville, KY 40201 ■ Toll-free: 1-800-814-2028 ■ Local: 502-778-2791 ■ Quote &amp; Order Fax: 1-800-444-0602



# HEAVY DUTY GAS RANGE

## 36" Wide Dual Plancha Gas Range

### INSTALLATION INSTRUCTIONS

1. A properly sized gas pressure regulator suitable for battery or single unit application must be furnished and installed. Natural gas 6.0" W.C., propane gas 10 W.C.
  2. An adequate ventilation system is required for commercial cooking equipment. Information may be obtained by writing to the National Fire Protection Association, 1 Batterymarch Park, Quincy, MA 02269, www.NFPA.org. When writing, refer to NFPA No. 96.
  3. These units are manufactured for installation in accordance with ANSZ223.1A (latest edition), National Fuel Gas Code. Copies may be obtained from The American Gas Association, 400 N Capitol St. NW, Washington, DC 20001, www.AGA.org.
  4. **Clearances**  

	Rear	Sides
Combustible	10"	10"
Non-combustible	0"	0"
  5. For proper combustion, install equipment on adjustable legs or casters. On curb or platform, allow 3/2" front overhand. Toe base with leveling bolts are required for curb installation. Specify when ordering.
  6. Cannot be battered with GH series equipment.
  7. This appliance is manufactured for commercial installation only and is not intended for home use.
- NOTE:** In line with its policy to continually improve its product, Vulcan reserves the right to change materials and specifications without notice.

**Specify type of gas when ordering.  
Specify altitude when above 2,000 feet.**

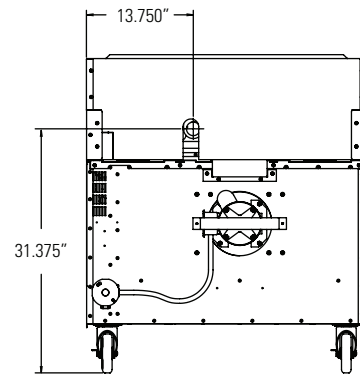
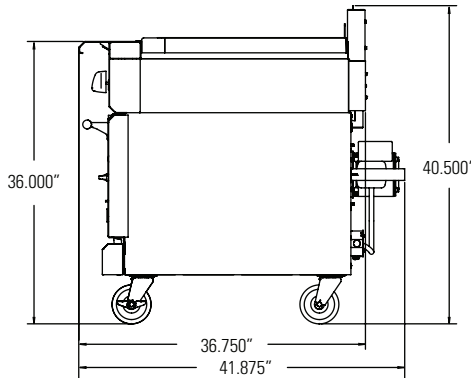
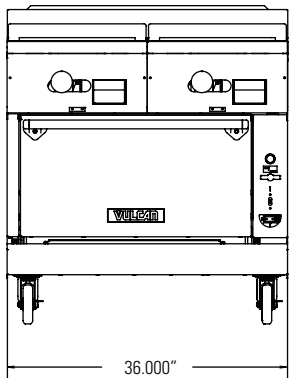
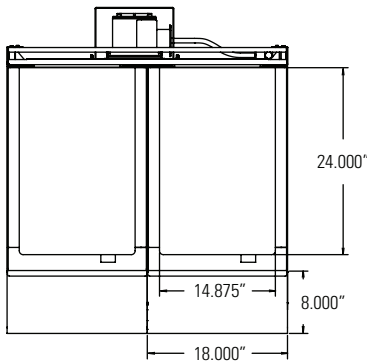

TOP CONFIGURATION	MODEL NUMBER	DESCRIPTION	TOTAL INPUT BTU / HR	SHIPPING WEIGHT LBS / KG
	V2P36	36" Wide Dual Plancha / Modular	35,000	404 / 183
	V2P36B	36" Wide Dual Plancha / Cabinet Base	35,000	504 / 229
	V2P36S	36" Wide Dual Plancha / Standard Oven	85,000	685 / 311
	V2P36C	36" Wide Dual Plancha / Convection Oven	67,000	763 / 346

This appliance is manufactured for commercial use only and is not intended for home use.



a division of ITW Food Equipment Group LLC

P.O. Box 696 ■ Louisville, KY 40201 ■ Toll-free: 1-800-814-2028 ■ Local: 502-778-2791 ■ Quote & Order Fax: 1-800-444-0602

**NOTE:** In line with its policy to continually improve its products, Vulcan reserves the right to change materials and specifications without notice.